

DoseGuard

with  ICAD[®]
INSIDE

Inline UV Monitoring &
Automatic Dose Control

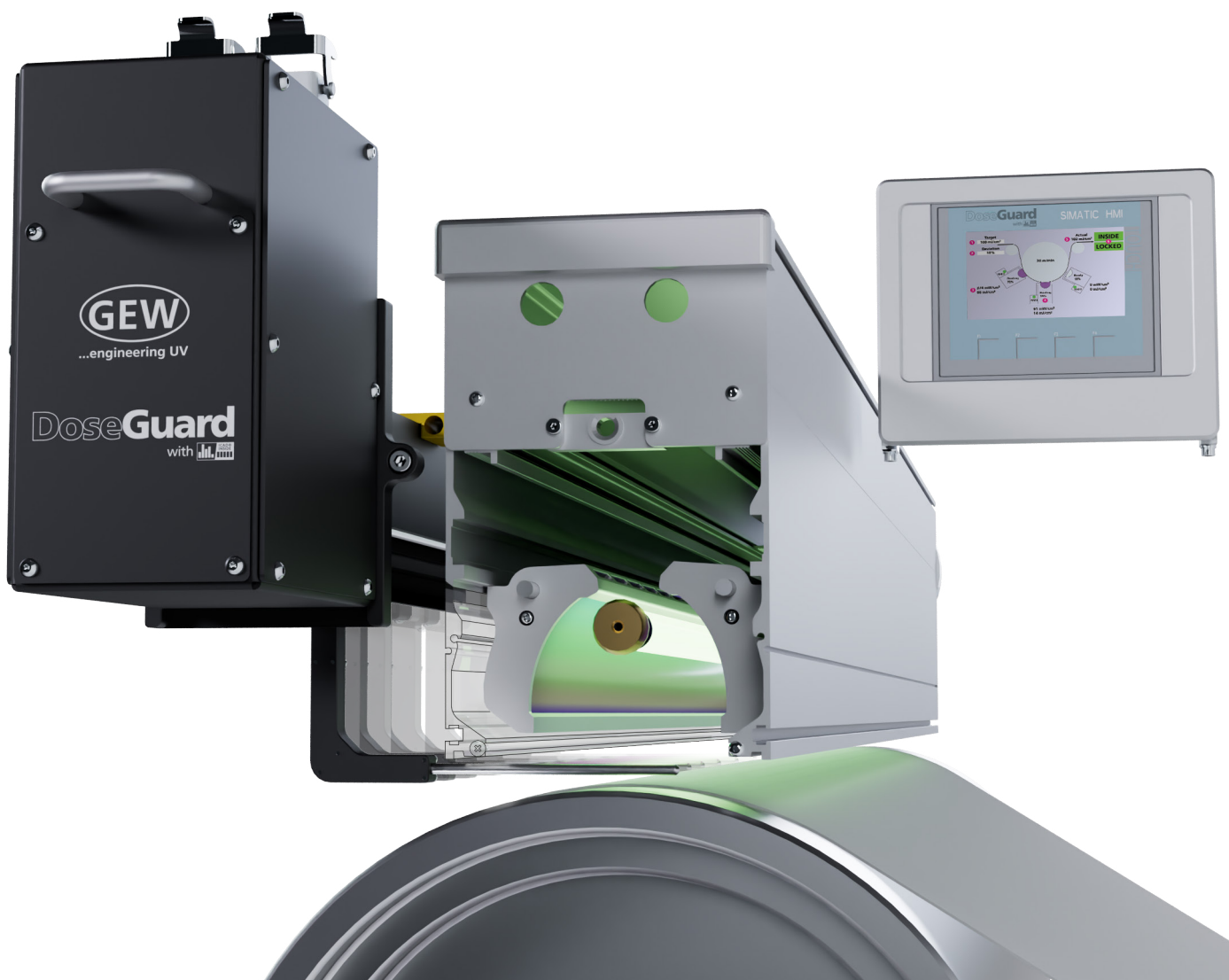

GEW precision control systems

gewuv.com



...engineering UV

DoseGuard

DoseGuard consists of a scanning optic (ICAD® unit) mounted underneath the lamp, which continuously measures the UV light that reaches the substrate, across the entire width of the system. It improves the UV curing process by automatically adjusting the power of your GEW UV lamps to maintain a target UV dose.

Benefits of DoseGuard

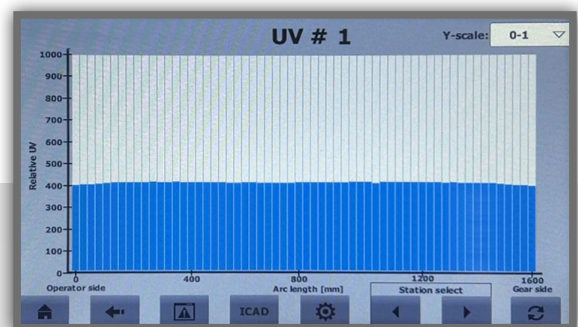
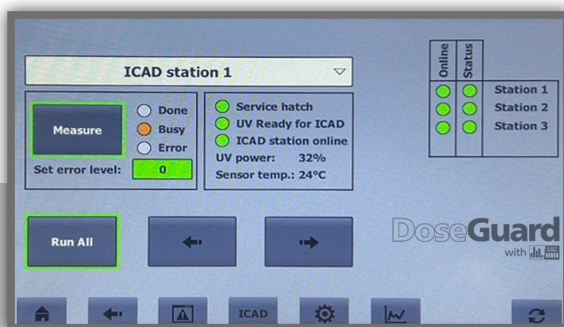
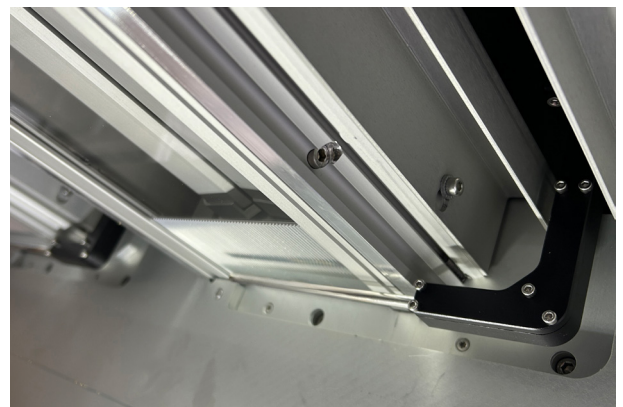
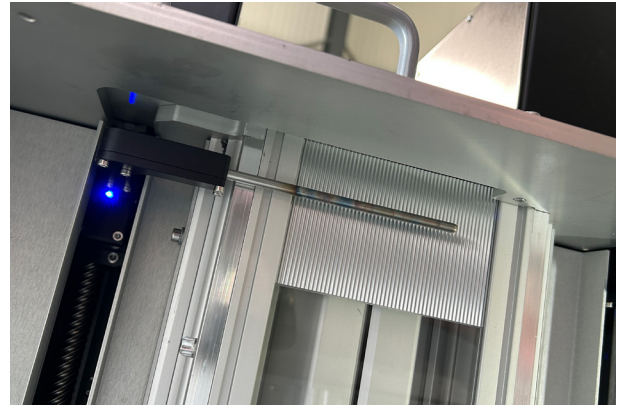
- **Perfect UV output control:** DoseGuard monitors the UV output of any UV lamp or LED across its entire width, and will issue a warning if the level of UV output delivered to the substrate changes during production, for any reason.
- **Guaranteed product quality and reduced waste:** Automatic dose control ensures your product is cured to exactly the correct level by adjusting UV output of each lamp to maintain the same UV dose delivered to the product, independent of speed or UV lamp condition, even for multiple lamps on a single print/coating station.
- **Reduced energy and maintenance costs:** Only use the exact power required to achieve good quality product by automatically optimising lamp power to deliver desired UV dose. This feature also increases lamp lifetimes and enables bulbs and reflectors to be used for longer.
- **Documentation for compliance or GMP:** Operational data can be exported via a software connection to the controller, or via ModBus protocol so that compliance documents or certificates of compliance can be generated by the customer.



DoseGuard can be set to scan each UV lamp or LED array individually, reporting any imperfections in UV output across the entire width.

Inline UV Dose Control

The ICAD® optic continuously measures UV lamp outputs and automatically opens shutters and adjusts power of each UV lamp to match the UV dose requirement. As speed and/or UV lamp conditions change, automatic dose control adjusts power levels in a matter of seconds to minimise waste and ensure consistent product curing at all times.

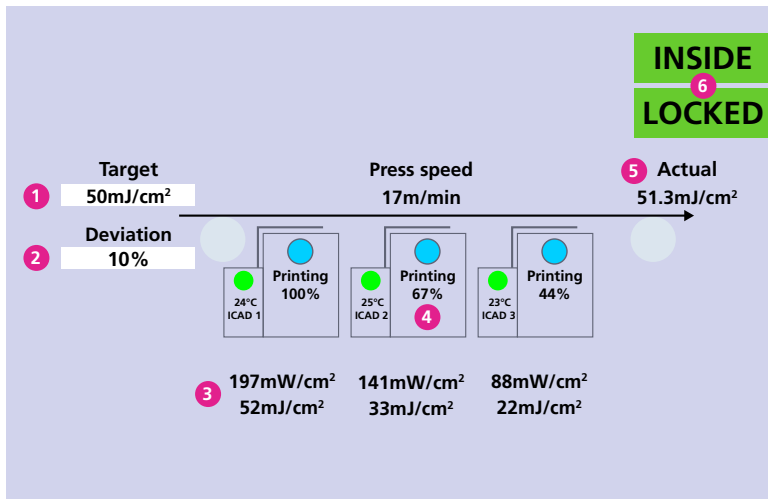
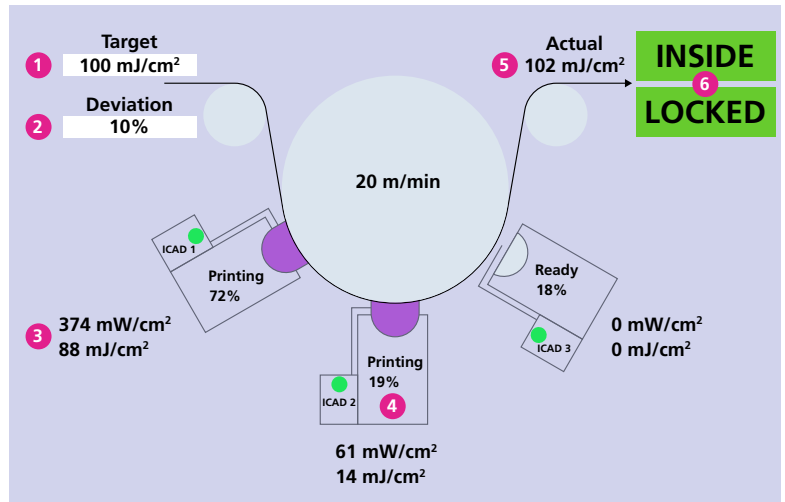

- 1 Customer sets target dose
- 2 Customer sets allowable deviation from target
- 3 Measured irradiance and calculated dose of each lamp
- 4 UV power and status of each lamp
- 5 Total UV dose of print/coating station
- 6 Dose status indicator:
 - Dose is INSIDE/OUTSIDE target
 - Lamp power levels are "LOCKED/ADJUSTING" – to indicate UV power levels are being changed automatically during e.g. acceleration of press.

Specifications

Resolution	1 mW/cm ²
Sample rate	128 samples/sec
Minimum cross section	320 mm H x 142 mm W
Maximum length	240 cm
Compatibility	Any GEW mercury or LED lamp
Connectivity options	Wi-Fi, ModBus
Calibration period	12 months

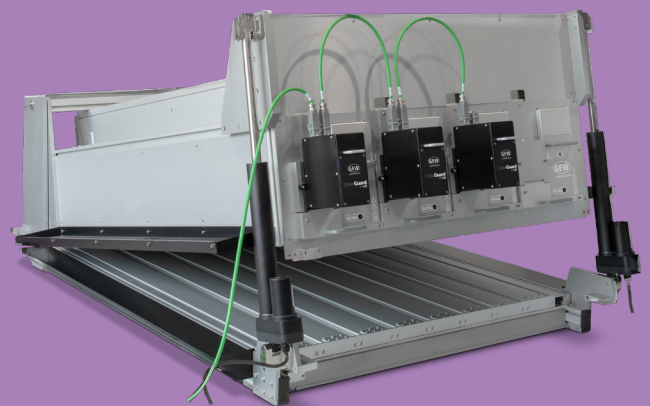

Scan to watch the video

Full Width UV Output Monitoring

The calibrated ICAD® radiometers are mounted beneath the UV lamp and measure irradiance at the focal point of the UV lamp, across its entire width.

They scan the whole UV lamp and measure changes in UV output from lamps and reflectors, but also detect spot contamination or degradation with age.

Operators can set a 'window of acceptance' and ICAD® can send warnings when output decreases below set values. The frequency of checks can also be adjusted.

When static, ICAD® radiometers park in a protected position away from contaminants and the substrate. Scan passes are very fast, thus avoiding any shadowing impact.

DoseGuard with ICAD® inside, enables inline and automated power level adjustment for a uniform and specific power distribution over the full length of the UV lamp or LED. It offers the benefit of continuous monitoring during production which increases quality, uptime and reduces the risk of producing waste.

DoseGuard Offline Lab Unit

DoseGuard technology is also available in the form of an offline laboratory unit, for the testing of individual lamp or LED cassettes.



For further information, please contact your GEW Sales Representative.

gewuv.com/dlu

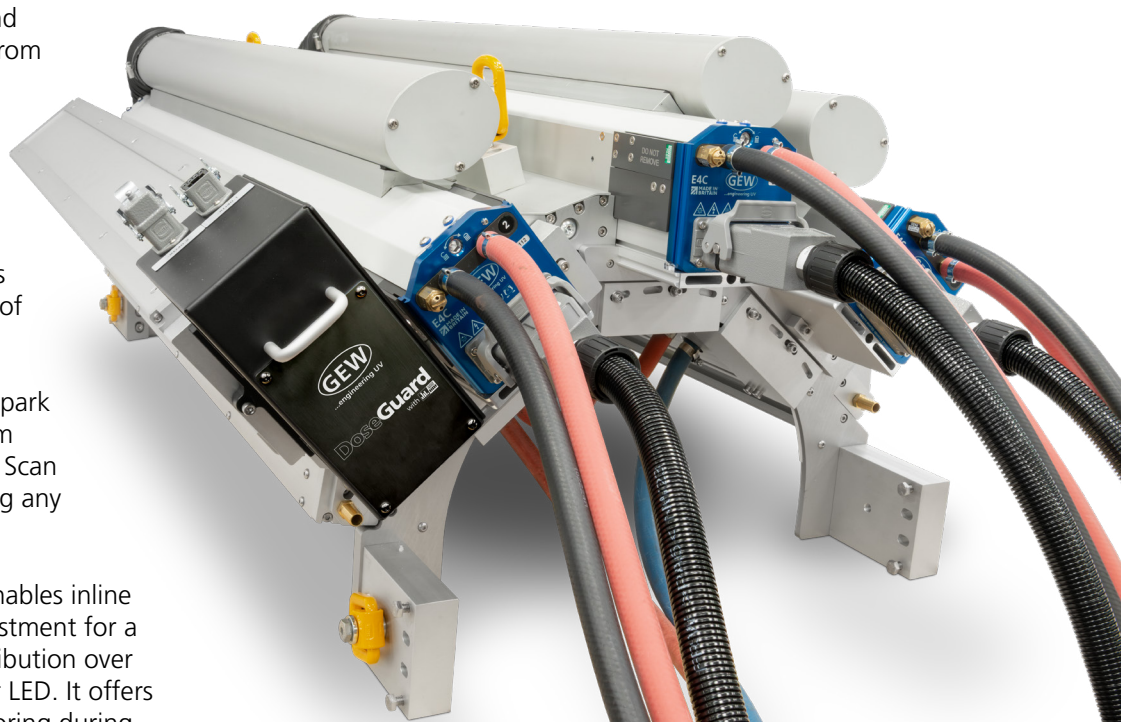

Full Width UV Output Monitoring

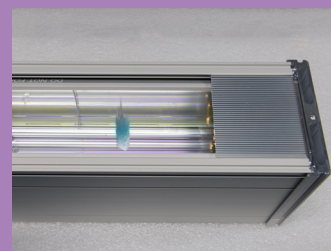

Example: ink stain on quartz window reduces UV dose by 48% under the contaminated area - this cannot be detected by online static sensors.

DOSEGWARD-UK/V3_6.2026



Head Office

GEW (EC) Limited, Crompton Way, Crawley RH10 9QR, UK

UK +44 1737 824 500 Germany +49 7022 303 9769 USA +1 440 237 4439

✉ sales@gewuv.com gewuv.com